



THE FORKLIFT



PPXsio20

Lithium-Ion Low Lift Pallet Truck
2.000 kg

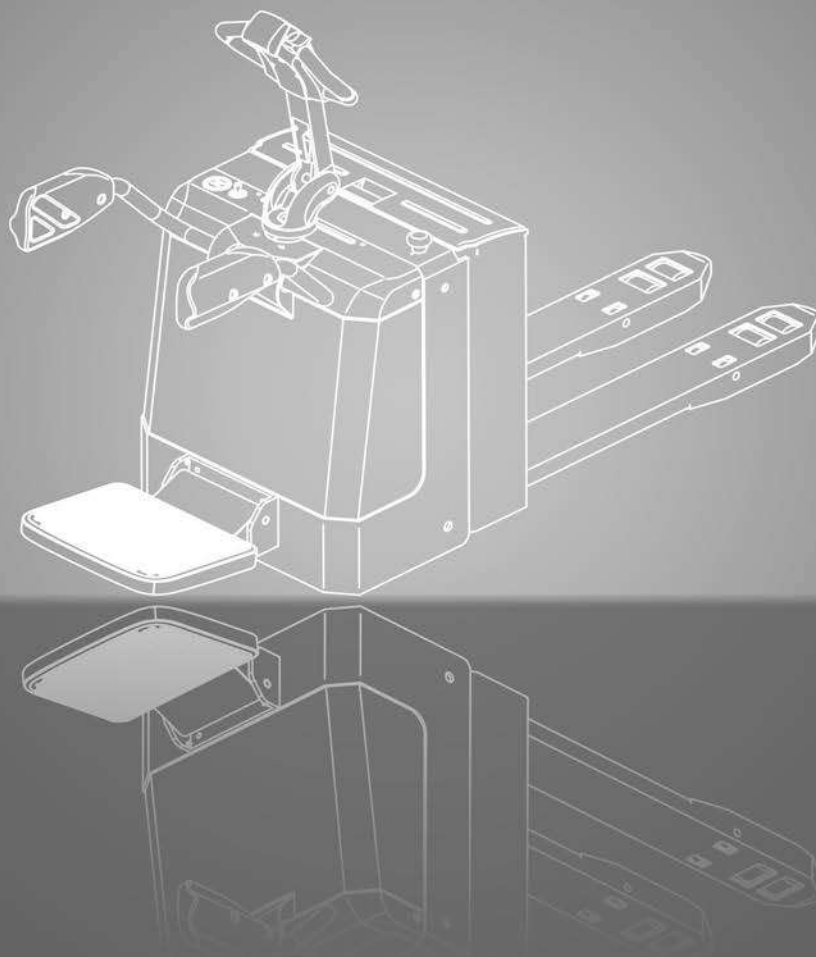

www.clarkmheu.com

DIMENSIONS

PPXsio20

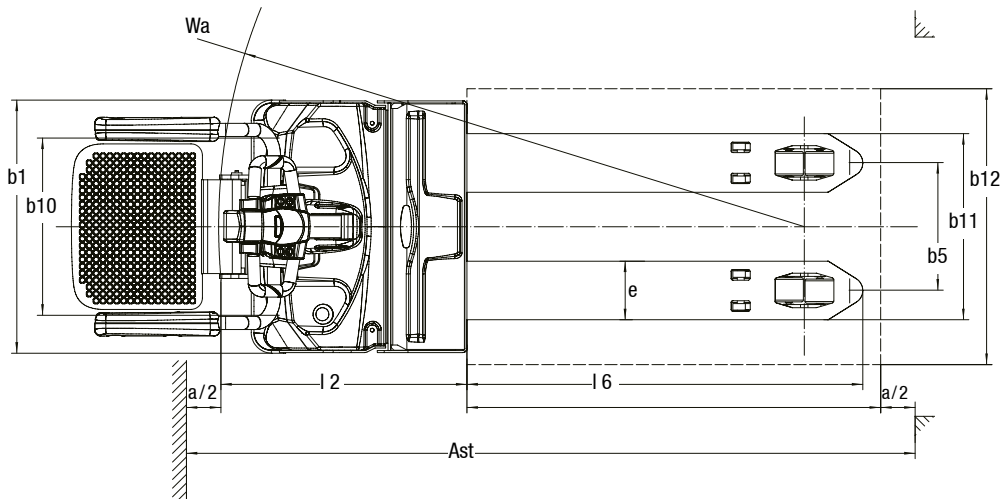
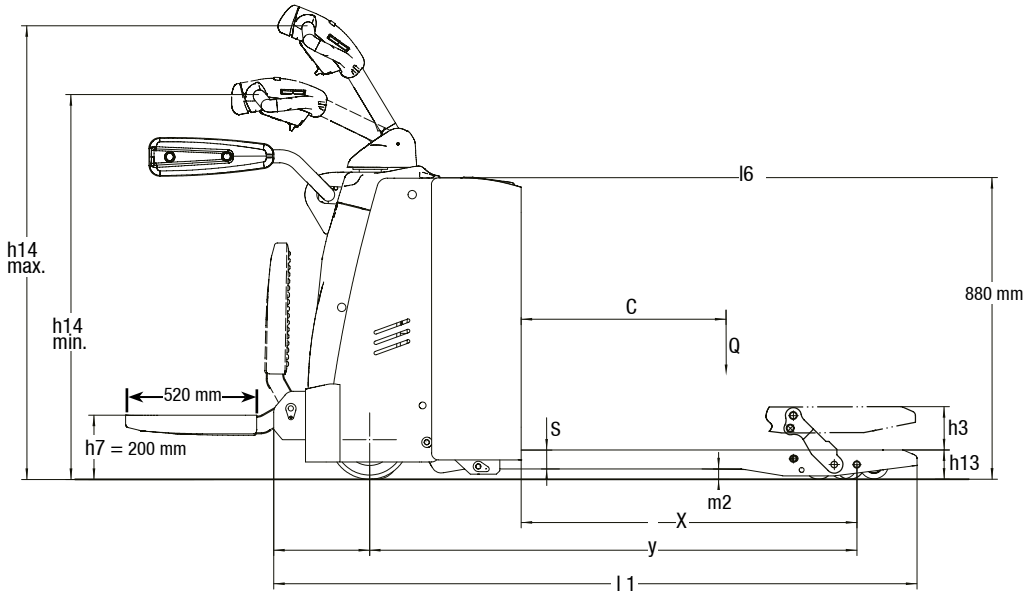

$$R_h = \sqrt{x^2 + \left(\frac{b_{12}}{2}\right)^2}$$

$$A_{st} = W_a + l_6 - x + a \quad \text{if} \quad R_h < W_a$$

$$A_{st} = R_h + l_6 - x + a \quad \text{if} \quad R_h > W_a$$

For corresponding data see
Specification Chart.

SPECIFICATIONS

Product Specification acc. to VDI 2198

1.1 Manufacturer (Abbreviation)		CLARK
Specifications	1.2 Manufacturer's designation	PPXsio20
	1.3 Drive	24V Electric
	1.4 Operator type	Stand-on / Pedestrian
	1.5 Rated capacity/rated load	Q (kg) 2.000
	1.6 Load centre distance	c (mm) 600
	1.8 Load distance	x (mm) 916
	1.9 Wheelbase	y (mm) 1.418
Weight	2.1 Service weight incl. battery (see 6.5)	kg 630
	2.2 Axle loading, laden front/rear	kg 1.020 / 1.610
	2.3 Axle loading, unladen front/rear	kg 500 / 130
Tyres, Chassis	3.1 Tyres	Polyurethane
	3.2 Tyre size, front	Ø 230 x 75
	3.3 Tyre size, rear	Ø 85 x 70 / Ø 83 x 115
	3.4 Additional wheels (dimensions)	Ø 130 x 55
	3.5 Wheels, number front/rear (x = driven wheels)	1 x + 2 / 4 / 1 x + 2 / 2
	3.6 Tread, front	b10 (mm) 510
	3.7 Tread, rear	b11 (mm) 370
Dimensions	4.4 Lift	h3 (mm) 120
	4.4 Lift height	h3 + h13 (mm) 205
	4.8 Stand height	h7 (mm) 200
	4.9 Height tiller in driving position min./max.	h14 (mm) 1.150 / 1.470
	4.15 Height, lowered	h13 (mm) 85
	4.19 Overall length (without platform)	l1 (mm) 1.930
	4.20 Length to face of forks (without platform)	l2 (mm) 762
	4.21 Overall width	b1 (mm) 730
	4.22 Fork dimensions	s • e • l (mm) 55 x 170 x 1.150
	4.25 Distance between fork-arms	b5 (mm) 540
	4.32 Ground clearance, centre of wheelbase	m2 (mm) 30
4.33 Aisle width for pallets 1.000 x 1.200 sideways	Ast (mm) 2.523	
4.34 Aisle width for pallets 800 x 1.200 lengthways	Ast (mm) 2.372	
4.35 Turning radius	Wa (mm) 1.700	
Performance	5.1 Travel speed, laden/unladen	km/h 9 / 12
	5.2 Lift speed, laden/unladen	m/s 0.050 / 0.054
	5.3 Lowering speed, laden/unladen	m/s 0.067 / 0.054
	5.8 Max. gradeability, laden/unladen *1	% 8.0 / 16.0
	5.10 Service brake	Electric
Electrics	6.1 Drive motor rating S2 60 min	kW 2,5
	6.2 Lift motor rating at S3 15 %	kW 2,2
	6.3 Battery acc. to DIN 43531/35/36 A, B, C, no	DIN 43535 B
	6.4 Battery voltage/nominal capacity (5hr)	V/Ah 24V / 210
	6.5 Battery weight	kg 70
	6.6 Energy consumption acc. to VDI cycle	kWh/h -
	- Battery type	Lithium-ion
	8.1 Type of drive unit	AC
Misc.	10.5 Steering design	Electronic
	10.7 Sound pressure level at the driver's seat acc. to EN 12053	dB(A) 74

*1) At friction coefficient $\mu=0.6$ with 1.6 km/h

All data refer to trucks in standard design.

Performance may vary + 5 % and - 10 % due to motor and system efficiency tolerance. The performance shown represents nominal values which may be obtained under typical operating conditions of a machine. CLARK products and specifications are subject to change without notice.

EQUIPMENT EXTRAS

		PPXsio20
General	Reliable low - maintenance AC traction motor	•
	Two castor wheels	•
	Pallet entry wheels	x
	Ergonomic operator platform	•
Drive and Battery Options	Travel speed 12 km / h	•
	Single load wheel (Polyurethane)	x
	Tandem load wheel (Polyurethane)	•
	Electric power steering	•
	Profiled traction wheel	x
	External charger (100 A) with 230-volt socket	•
	Battery discharge indicator	•
	Battery compartment sizes: 210 Ah batteries	•
Dimensions	Distance between fork-arms: 540 mm	•
	Distance between fork-arms: 600 mm / 685 mm	x
	Fork length: 1.150 mm	•
	Fork length: 850 mm, 1.000 mm, 1.220 mm, 1.450 mm, 2.000 mm, 2.400 mm	x
Safety	Key switch activation	•
	Automatic lift stop at max. lift	•
	Automatic parking brake	•
	Comfort and safety tiller	•
	Control of all drive commands left - and right - handed	•

• = Standard Equipment; x = Option

FEATURES & ADVANTAGES

PPXsio20

Electrical lift and manual lowering

- Sensitive lifting and lowering
- Drive and operating controls in easy reach position
- Automatic braking when the control arm is released
- Suitable for both left- and right-handed users

Display

- Battery discharge indicator
- Operating hour counter
- Battery management system
- On-board diagnostics via error code

Application

- For use on medium to long transport routes
- Powerful 24 Volt drive with Li-ion-Power
- Smooth and quiet operation
- Always usable with the lithium-ion battery from top-up charging
- Quick charging times
- Manoeuvrable in the tightest of spaces due to folding platform
- Programmability for adapted driving behavior

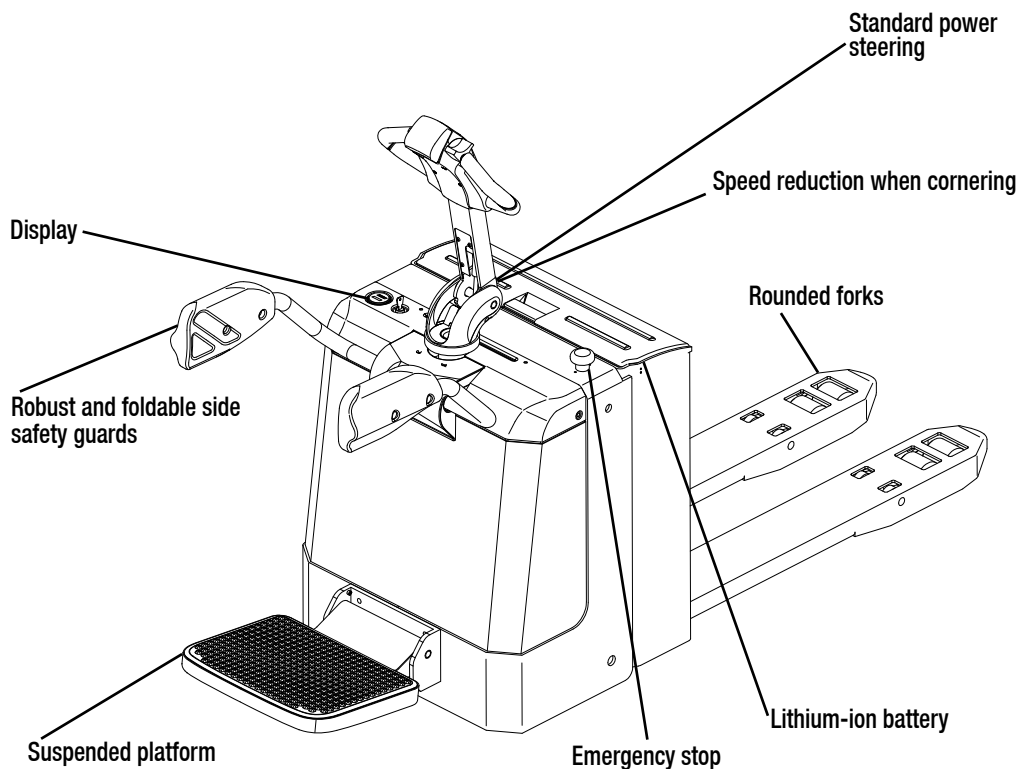

PRODUCT DESCRIPTION



The CLARK lithium-ion low lift pallet truck PPXsio20 is a robust and stable low lift pallet truck designed for industrial use on medium to long transport distances. Whether for loading and unloading trucks or for heavy material transport in warehouses, CLARK warehouse technology is designed for hard applications. Intermediate loads can prevent downtimes for reloading. The Li-Ion battery thus ensures maximum availability. Even during long periods of use, no battery change is necessary - due to the intermediate charging capability. As the Li-Ion battery does not release any gases during charging, no ventilated charging chambers are necessary.

Operator Platform

The foldable operator platform is standard for the PPXsio20 increases both safety and comfort. The platform can be folded up manually and is ideal for use even in confined spaces. The low level standing height makes it easy to get on and off the unit during operation. If the driver steps off the platform, the unit automatically switches to standby mode and the unit can no longer be operated. In application with activated side safety guards, maximum driving speeds of up to 12 km/h are possible. When the side safety guards are closed, the maximum driving speed is automatically reduced.

Productivity

All operation functions for lifting, lowering and driving are positioned in an ergonomic safety tiller handle with easy to reach switches. This allows the operator to concentrate solely on the conveyance process. The speed reduction during cornering ensures a high level of safety in curves.

Advantages of Lithium-ion technology

Top-up charging can be used between full charges without affecting the service life of the battery. The battery can be recharged with any 230-V socket. Up to 7% of battery capacity can be recharged in just 10 minutes.

Reliability

CLARK has used tried and tested components and materials in the design of the low-platform trucks and built them solidly to ensure a long service life, high performance and safety.

CLARK Europe GmbH
Dr.-Alfred-Herrhausen-Allee 33
47228 Duisburg / Germany
Tel.: +49 (0)2065 499 13-0
Fax: +49 (0)2065 499 13-290
E-Mail: Info-europe@clarkmheu.com
www.clarkmheu.com

Dealer:



Nr.: 4579?? 08/2020

Valid for Lot-no.: PPXsio20: 8300