



THE FORKLIFT



WS10M WS10

Electric Stacker Trucks
1.000 kg

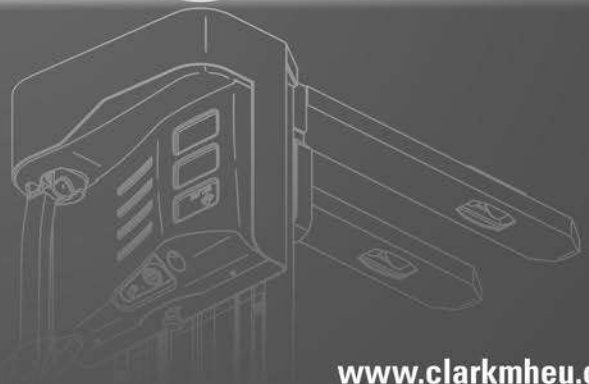
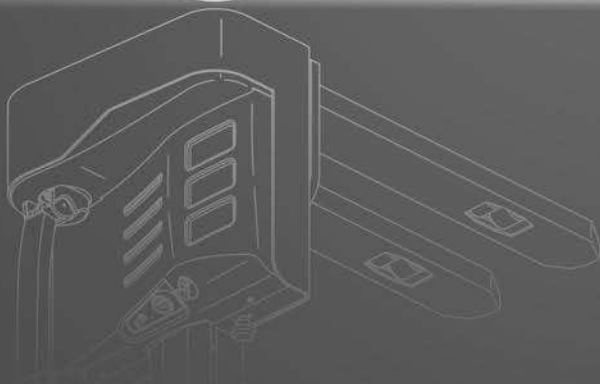
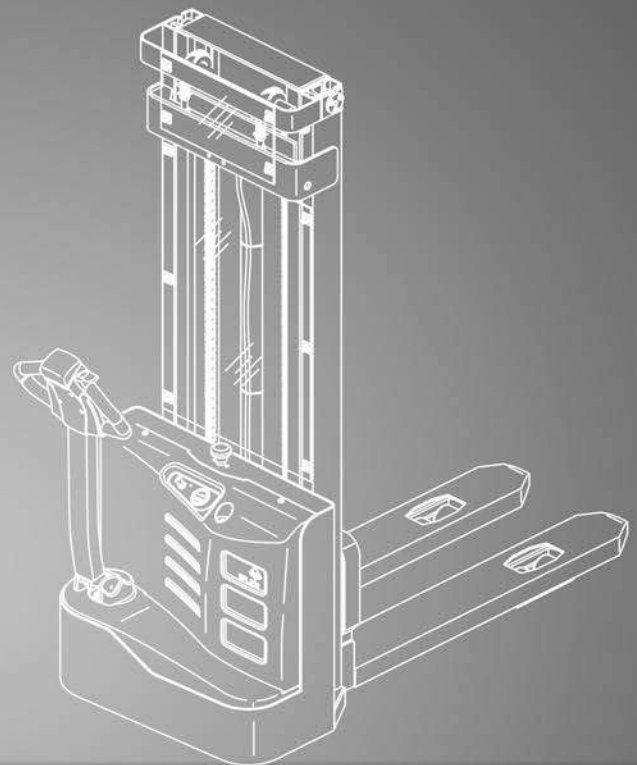
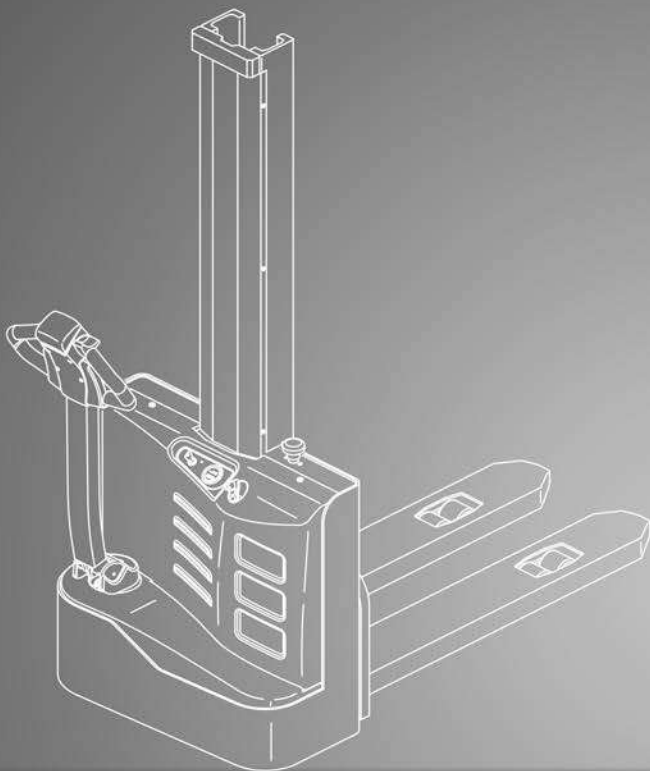

DIMENSIONS

WS10M
WS10

$$R = \sqrt{(l_6 - x)^2 + \left(\frac{b_{12}}{2}\right)^2}$$

$$R_h = \sqrt{x^2 + \left(\frac{b_{12}}{2}\right)^2}$$

$$A_{st} = W_a + R + a \text{ if } R_h < W_a$$

$$A_{st} = R_h + R + a \text{ if } R_h > W_a$$

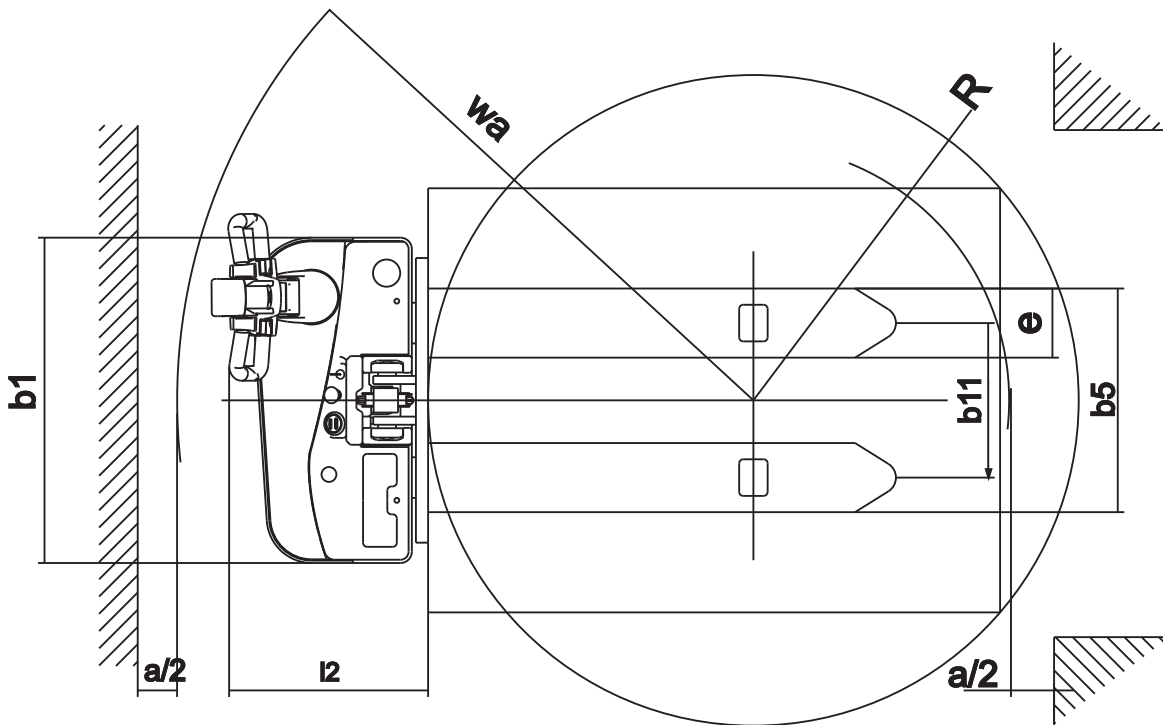
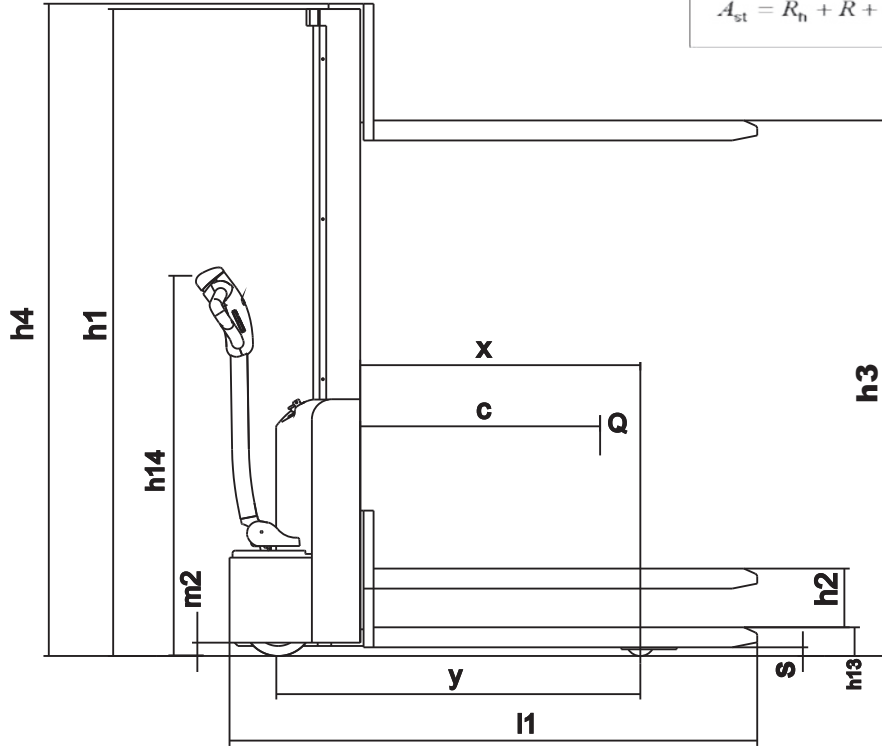

SPECIFICATIONS

Product Specifications acc. to VDI 2198

1.1 Manufacturer (Abbreviation)		CLARK	CLARK	
Specifications	1.2 Manufacturer's designation	WS10M	WS10	
	1.3 Drive	24V Electric	24V Electric	
	1.4 Operator type	Pedestrian	Pedestrian	
	1.5 Rated capacity/rated load	Q (kg)	1000	1000
	1.6 Load centre distance	c (mm)	600	600
	1.8 Load distance	x (mm)	805	795
	1.9 Wheelbase	y (mm)	1126	1240
Weight	2.1 Service weight incl. battery (see 6.5)	kg	462	533
	2.2 Axle loading, laden front/rear	kg	641/821	634/851
	2.3 Axle loading, unladen front/rear	kg	343/119	413/120
Tyres, Chassis	3.1 Tyres	Polyurethane	Polyurethane	
	3.2 Tyre size, front	Ø 210x70	Ø 210x70	
	3.3 Tyre size, rear	Ø 80x60	Ø 80x60	
	3.4 Additional wheels (dimensions)	Ø 130x55	Ø 130x55	
	3.5 Wheels, number front/rear (x = driven wheels)	1x + 1/4	1x + 1/4	
	3.6 Tread, front	b10 (mm)	533	533
	3.7 Tread, rear	b11 (mm)	380	400
Dimensions	4.2 Height, mast lowered	h1 (mm)	1940	2022
	4.3 Free lift	h2 (mm)	1505	85
	4.4 Lift *1	h3 (mm)	1515	2915
	4.4 Lift height	h3 + h13 (mm)	1600	3000
	4.5 Height, mast extended	h4 (mm)	1955	3480
	4.9 Height tiller in driving position min./max.	h14 (mm)	860/1200	860/1200
	4.15 Height, lowered	h13 (mm)	85	85
	4.19 Overall length	l1 (mm)	1615	1740
	4.20 Length to face of forks	l2 (mm)	465	590
	4.21 Overall width	b1 (mm)	800	800
	4.22 Fork dimensions	s • e • l (mm)	60x170x1150	55x160x1150
	4.25 Distance between fork-arms	b5 (mm)	550	560
	4.32 Ground clearance, centre of wheelbase	m2 (mm)	30	30
	4.34 Aisle width for pallets 1000 x 1200 sideways	Ast (mm)	2126	2242
4.34 Aisle width for pallets 800 x 1200 lengthways	Ast (mm)	2057	2177	
4.35 Turning radius	Wa (mm)	1295	1408	
Performance	5.1 Travel speed, laden/unladen	km/h	3.5/4.0	3.5 /4.0
	5.2 Lift speed, laden/unladen	m/s	0.12/0.22	0.12/0.22
	5.3 Lowering speed, laden/unladen	m/s	0.12/0.11	0.12/0.11
	5.8 Max. gradeability, laden/unladen *2	%	3/10	3/10
	5.10 Service brake		Electric	Electric
Electrics	6.1 Drive motor rating S2 60 min	kW	0.65	0.65
	6.2 Lift motor rating at S3 15 %	kW	2.2	2.2
	6.3 Battery acc. to DIN 43531/35/36 A, B, C, no		No	No
	6.4 Battery voltage/nominal capacity	Ah/5hr	24V/72Ah	24V/72Ah
	6.5 Battery weight	kg	2 x 25	2 x 30
	6.6 Energy consumption acc. to VDI cycle	kWh/h	-	-
	- Battery type		Block batteries	Block batteries
	8.1 Type of drive unit		DC	DC
10.5 Steering design		Mechanical	Mechanical	
Misc.	10.7 Sound pressure level at the driver's seat acc. to EN 12053	dB(A)	65	64

*1) Further lift heights see upright table

*2) At friction coefficient $\mu=0.6$ with 1.6 km/h

PRODUCT DESCRIPTION

Application

- Suitable for low intensity applications.
- Optimum starter unit in the high lift stacker market.
- Easy flexible manoeuvrability.
- 2,2kW output powerful lift motor.

Safety

- Simple operator control implementation.
- Driving speed adjustment from 500 mm lifting height.
- Automatic release tiller arm position for cushioned reverse and neutral breaking.
- Ergonomic tiller handle buttons.
- Operation controls can be easily accessed for left and right hand use.
- Emergency stop switch.

Automatic Parking Brake

- Safe operation on gradients and ramps.
- Automatic parking brake only released when the driving switch is activated.

Battery and Charging Technology

- Battery discharge indicator and operating hour counter.
- Maintenance-free block batteries (gel technology) with 24V/72Ah.
- Optional maintenance-free block batteries (AGM technology) with 24V/82Ah.
- Integrated battery charger can be used with every standard 230V socket.

GENERAL DATA

Upright table WS10M

Mast type	Lift height (h3+h13)	Mast lowered (h1)	Mast extended (h4)	Free lift (h2)
	mm	mm	mm	mm
Mono	1600	1940	1955	1505
	1950	2290	2305	1855

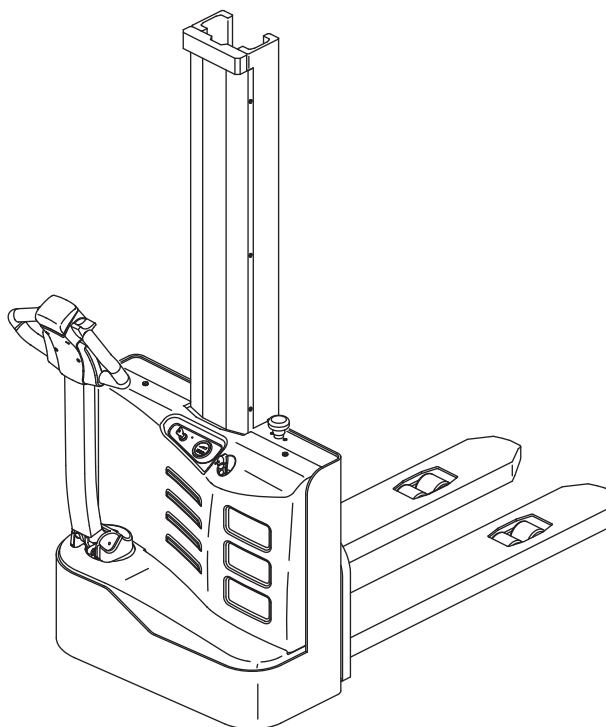

Upright table WS10

Mast type	Lift height (h3+h13)	Mast lowered (h1)	Mast extended (h4)	Free lift (h2)
	mm	mm	mm	mm
Standard	2500	1772	2987	85
	2700	1872	3187	
	3000	2022	3487	
	3300	2172	3787	

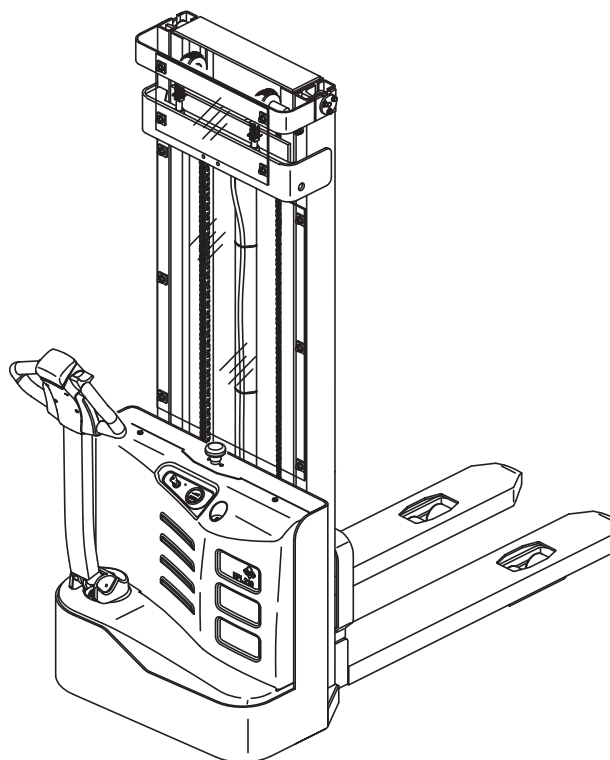

FEATURES & EQUIPMENT EXTRAS

	WS10	WS10M
Traction wheel (Polyurethane)	•	•
Profiled traction wheel	x	x
Tandem load wheel (Polyurethane)	•	•
Maintenance-free block batteries (Gel)	•	•
Maintenance-free block batteries (AGM)	x	x
Integrated on-board charger	•	•

• = Standard Equipment; x = Option

CLARK Europe GmbH
Dr.-Alfred-Herrhausen-Allee 33
47228 Duisburg / Germany
Tel.: +49 (0)2065 499 13-0
Fax: +49 (0)2065 499 13-290
E-Mail: Info-europe@clarkmheu.com
www.clarkmheu.com

Dealer:

